



EVOLUTION STEEL CAVITY UNIT



THE STRONGER CAVITY UNIT

- ✓ Premium Galvanised Steel Cavity Unit
- ✓ Improved back post for added strength & stability
- ✓ Easily adapt from Flush Jamb to Flush Pull with new Cavity Converter
- ✓ Redesigned base channel provides strength & secure floor fixing during installation
- ✓ Approved for Direct Tile Application
- ✓ Ideal for Wet Areas and Tiled Walls

Experience the next generation Evolution Steel Cavity Unit - now upgraded to deliver even greater strength and stability. Featuring increased steel thickness in both the split jamb and back post, along with a redesigned base channel and reversed channel back post to enhance rigidity during transport and installation. It has been tested and approved for direct tile application and comes standard with our new cavity converter for seamless adjustment from flush jamb to flush pull on-site. The Evolution Steel Cavity Unit is the perfect solution for both residential and commercial projects, offering strength, flexibility, and hassle-free installation.



CAVITY UNIT

EVOLUTION STEEL

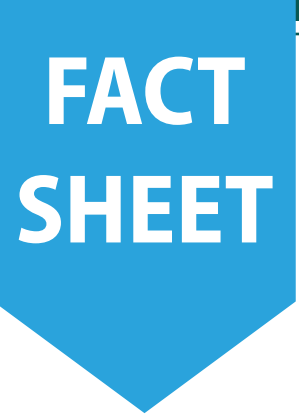

FEATURES



IMPROVED BACK POST

Reversed Channel provides extra strength
Helps prevent damage during transport
Less cavity movement during installation

REFINED MANUFACTURING

1.55mm thick steel for Back Post & Split Jamb
Provides extra strength & rigidity
Clinch fixed for extra strength

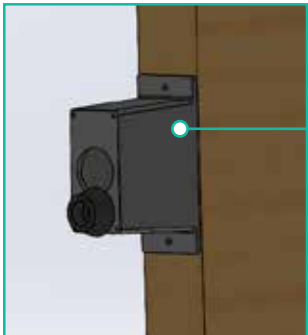
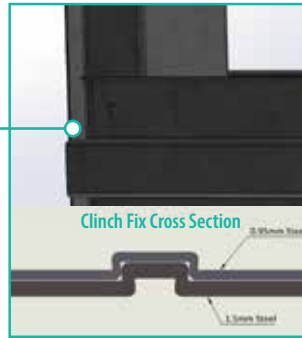

INCLUDES NEW CAVITY CONVERTER

Convert your Flush Jamb cavity to Flush Pull on-site
Cavity Converter included with every unit as standard
For Flush Pull cavities door protudes 50mm

REDESIGNED BASE CHANNEL/NOGGIN

Full-length base channel provides support during transport
Dedicated fixing points provide secure floor fixing
Improved stability during installation

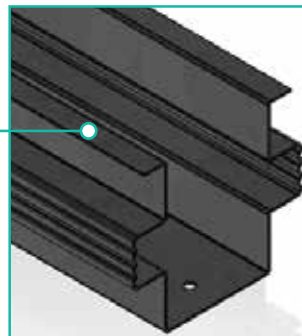

APPROVED FOR DIRECT TILE APPLICATION

Independently tested & approved for direct tile application Tested for max load of 45kg/m²
Install with confidence - Hume provide detailed instructions

SPECIFICATIONS

Range:	Evolution Steel Cavity
Stud Sizes:	64mm 70mm 90mm
Sheeting Material Thickness:	10mm (70 / 90mm Stud) 13mm (64 / 70 / 90mm Stud) <small>*Specify thickness on order</small>
Cavity Material:	Galvanised Steel
Suits Door Heights:	2040mm
Suits Door Widths:	620mm 720mm 770mm 820mm 870mm 920mm
Custom Sizes	Available POA
Max Door Mass:	70kg





THE SUPERIOR METAL CAVITY UNIT





- Engineered to be strong & durable
- Termite proof galvanised steel
- Available to suit 64mm steel stud walls
- 64mm stud walls suits 13mm sheeting only
- Option with - Soft closer
- Option with - One touch operation

Additional Extras	
Soft Closer	Additional \$74
Evolution Touch	Additional \$43
Closing Jamb	Additional \$68
CavityTrack Door Stop - For double cavity application	\$46 each
Double Adaptor Kit - For double cavity application	P.O.A.
Cavity Guide	\$12 a pair
Staingrade upgrade	Additional \$104
Timber Pelmet to suit double Cavity Unit	P.O.A.

■ ADD ON OPTIONS FOR EVOLUTION TIMBER & EVOLUTION STEEL

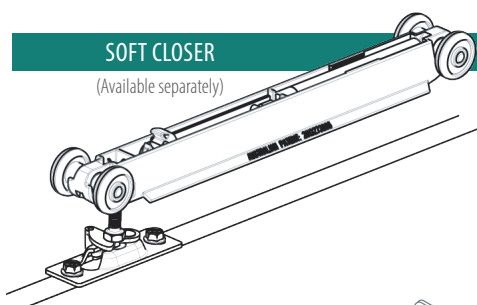
SOFT CLOSER
(Available separately)





Scan QR-code for Soft Closer installation video

CAVITY TRACK DOOR STOP
(For double cavity application)

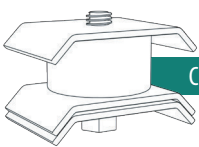

ONE TOUCH RELEASE
(Available separately)

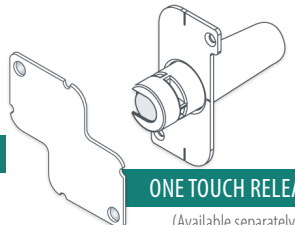

■ Cancellations or alterations for made to order doors will only be accepted on the day of ordering



INTERNAL SYSTEMS CAVITY UNITS

■ Cavity Units are recommended for 35mm doors only



FEATURES	EVOLUTION TIMBER	EVOLUTION TIMBER COMPLETE	EVOLUTION STEEL CAVITY (ASPIRE)	EVOLUTION STEEL COMPLETE (ASPIRE)
Smooth 4 Wheel Ball Bearing Carriages	✓	✓	✓	✓
Jump free U track - Smooth operation	✓	✓	✓	✓
Quick release mechanism	✓	✓	✓	✓
Maximum door mass 70kg	✓	✓	✓	✓
Same architrave height as a hinged door	✓	✓		
One Touch Release System		✓		✓
Soft Closer Technology		✓		✓
Tough Composite Split Jamb			✓	✓
Galvanised steel back posts slats & track - Termite resistant			✓	✓

CAVITY UNITS	Standard Size (mm)	Stud Thickness (mm)	
EVOLUTION TIMBER	2040x620/720/770/820	70/75/90/100	336
	2040x870	70/75/90/100	349
	2040x920	70/75/90/100	417
	2340x620/720/770/820	90/100	609
	2340x870	90/100	621
	2340x920	90/100	693
	Custom Size up to 2340x919	90/100	714
	Custom Size from Min 2340x919 - Max 2400x1200	90/100	789
EVOLUTION TIMBER COMPLETE	2040x620/720/770/820	70/75/90/100	443
	2040x870	70/75/90/100	457
	2040x920	70/75/90/100	513
	2340x620/720/770/820	90/100	718
	2340x870	90/100	730
	2340x920	90/100	802
	Custom Size up to 2340x919	90/100	822
	Custom Size from Min 2340x919 - Max 2400x1200	90/100	897
EVOLUTION STEEL (ASPIRE)	2040x620/720/770/820	64/70/90	406
	2040x870	64/70/90	440
	2040x920	64/70/90	503
	Custom Size	64/70/90	P.O.A.



EVOLUTION TIMBER CAVITY UNIT OPENING SIZES

A = Door height + 70mm (QLD, WA)
A = Door height + 80mm (NSW, VIC, ACT, SA, TAS)

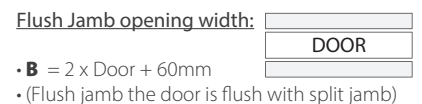
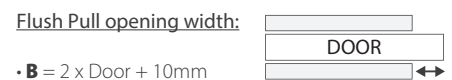

- Evolution Steel Complete (Aspire) P.O.A.
- Evolution Steel Cavity with 64mm stud suits 13mm sheeting material only